



STAFF & ORNEMENTS



GARABOS

PLATRERIE - STAFF



3 GÉNÉRATIONS DE SAVOIR-FAIRE ET D'EXIGENCE

Pierre Garabos, plâtrier traditionnel de formation, crée son entreprise à Carignan dans les années 60. « À cette époque, on plâtrait plafonds et murs à la tâche, on bossait le samedi et le dimanche matin ». Comme il le souligne encore régulièrement, trainer une corniche sur place ou monter un escalier sur voûte sarrasine était alors aussi normal que réaliser un doublage en plaques de plâtre de nos jours. Il n'imaginait probablement pas que l'entreprise Garabos ferait partie, 60 ans plus tard, de l'une des dernières entreprises de plâtrerie et de staff de la région bordelaise, faisant d'elle un acteur incontournable dans le domaine.

Grâce à ses deux fils, Bruno et Jean-Claude, l'entreprise Garabos prend dans les années 80 un tournant en se diversifiant dans la plâtrerie sèche, au plus grand damne de Pierre. Toutefois, Bruno, dont le cœur de métier reste la plâtrerie traditionnelle paternelle, met un point d'honneur à former de nombreux apprentis, afin de perpétuer les traditions et valeurs artisanales ancestrales du métier.

Cette alliance entre deux métiers distincts, l'un moderne et l'autre traditionnel, permis à l'entreprise de répondre aux attentes de nombreux architectes et l'amena rapidement à se diversifier une fois de plus, cette fois dans le staff, un métier axé autour de la décoration qui consiste à fabriquer et poser des éléments d'ornementation composés de plâtre et de liant végétal.

En 2023, l'entreprise dispose d'un savoir-faire reconnu dans ces trois métiers. Le goût du travail bien fait, du beau, et les défis techniques sont devenus les moteurs, le carburant, de toute l'équipe. Chaque challenge technique ou esthétique représente pour nous un nouveau moyen de mettre à l'épreuve nos compétences, notre technicité ou notre ingéniosité.

Le staff, grâce à l'énorme quantité de possibilité qu'il offre, représente pour l'entreprise un incroyable terrain de jeu, un inépuisable champ d'expression pour nos compagnons. Il est donc logique que l'entreprise vous présente aujourd'hui, sa propre gamme de staff.

Nous espérons que si cette dernière vous permet de choisir des modèles pour vos projets, elle ne limitera pas votre imagination, car les petites fantaisies de nos clients, ou les grandes, sont les raisons pour lesquelles nous nous levons avec le sourire le matin.

Boris G.

LE STAFF

CHEZ GARABOS



Le staff est un matériau à base de plâtre armé de fibre.

Inventée au 19^{ème} siècle, cette technique de moulage et de fabrication permet de créer et recréer des ornements de toutes tailles, formes ou styles.

Bien que cette technique de moulage du plâtre soit perçue comme une facette traditionnelle des métiers de la plâtrerie, l'alliance entre les nouvelles technologies (BIM, scan 3D, modélisation des ouvrages, recours à la réalité augmentée sur chantier etc...) et le staff, est possible, rendant au staffeur sa place au sein de projets neufs à hautes valeurs ajoutées.

Notre équipe est composée du bureau d'étude et de l'atelier.

Les deux Mathieu, Hervé, Daphné, Laura et Joel élaborent les calibres et les moules, destinés à exaucer tous les désirs des architectes et décorateurs.

Le bureau d'étude quant à lui, grâce à l'expérience de Jean-Claude, celle de Luc et David et à l'attention d'Allison, analyse les projets afin de proposer à nos clients les méthodes les plus adaptées et les plus en adéquation avec ses attentes tant esthétiques que techniques.

La force de Garabos réside dans l'association parfaite de ces fonctions : la compétence technique, l'analyse des contraintes, et les conseils judicieux.

Challengez-nous !



UNE GAMME HISTORIQUE

Rentrer dans un atelier de staff, c'est un peu comme franchir les portes d'un antiquaire de la rue Notre Dame. On y trouve de tout, de temps et d'époques plus ou moins révolus, et seul un fin connaisseur est réellement capable de comprendre la valeur véritable de ce qui s'y trouve.

En effet, le staffeur a l'encombrante manie de systématiquement récupérer, démonter, ou mouler tout ornement qu'il trouve ou répare sur un chantier afin de toujours disposer d'un double, pour être en mesure de le reproduire ailleurs.

L'atelier de l'entreprise Garabos ne déroge pas à ces règles. On peut y trouver bon nombre de corniches, de moulures, de rosaces ou de panneautages muraux que nous avons préservé de la destruction ou restitué à l'identique dans des lieux emblématiques du bordelais.

La gamme que nous vous proposons donne un petit aperçu des profils que nous stockons dans nos archives. Notre objectif est que cette gamme s'étoffe dans le temps, afin que chacun, en fonction de son projet, de la taille des pièces à décorer, du style ou d'une époque, puisse y trouver son bonheur.

SOMMAIRE

/1

LES CORNICHES p.8

ART DECO p.10

LUMINEUSE p.11

DOUCINE p.12

GORGE p.13

LARMIER p.18

CLASSIQUE p.20

/2

**LES MOULURES
ET CIMAISES** p.22

MOULURES p.24

CIMAISES p.32

/3

LES ROSACES p.34

/4

LES PANNEAUX p.40

/5

**CHAMBRANLES
et PLINTHES** p.44





LES CORNICHES

ART DÉCO

ABZAC

50.00 € /ml

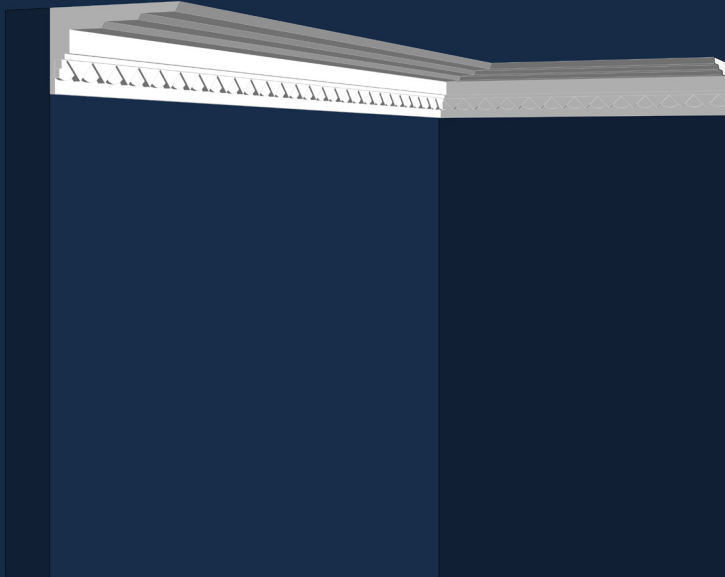

27.3

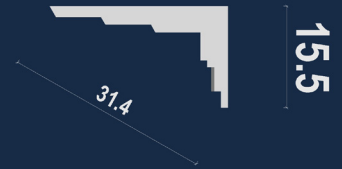

15.5

31.4

ARSAC

38.00 € /ml

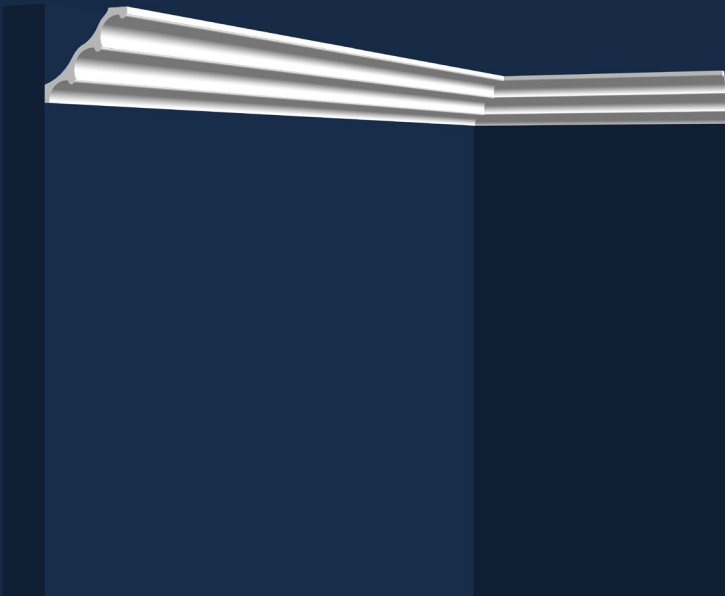

18.5



16.7

24.9

BALIZAC

45.00 € /ml

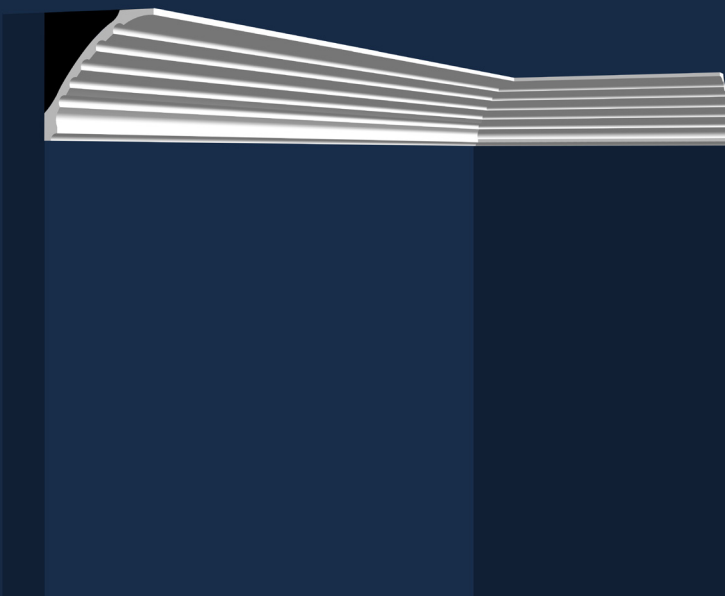

24.2



23.2

33.5

LUMINEUSE

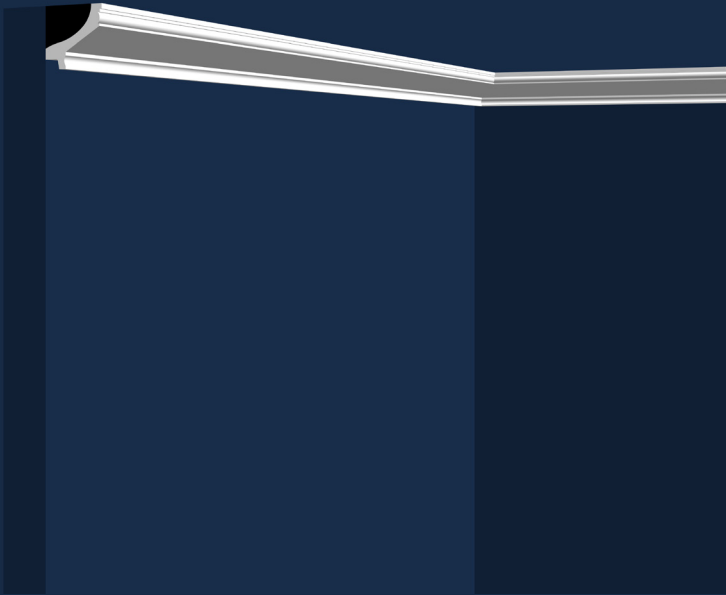

BIEUJAC

26.00 € /ml

12.7



11.5

16

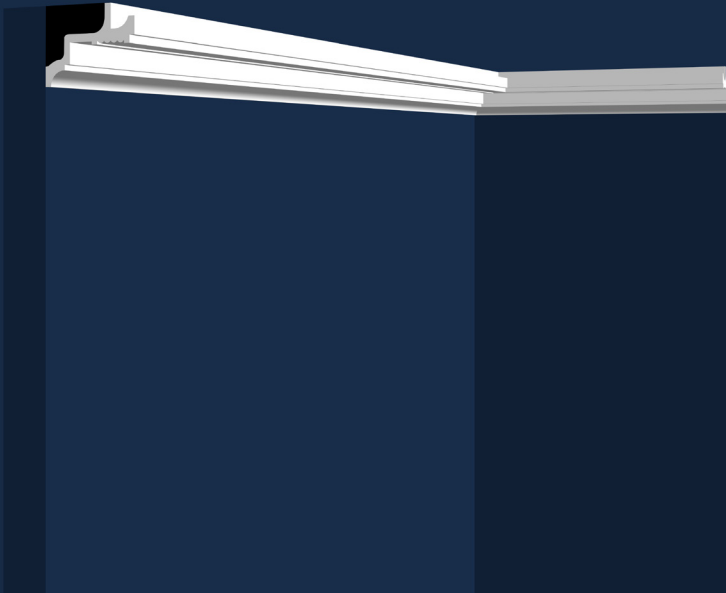

BONZAC

38.00 € /ml

19.9

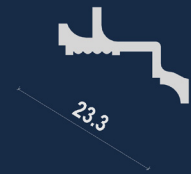

14.7

23.3

DOUCINE

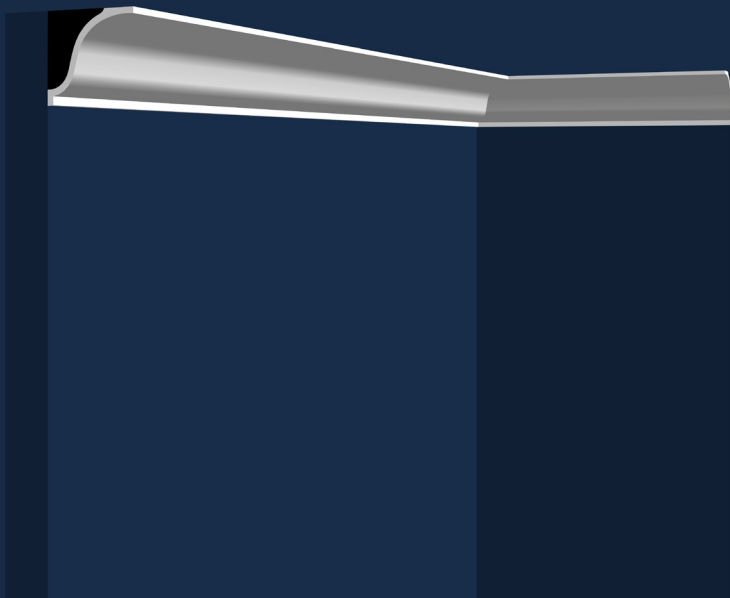

BOULIAC

36.00 € /ml

19.2

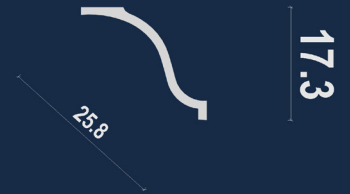

17.3

25.8

CABANAC

26.00 € /ml

12.8



9.4

15.9

CADARSAC

22.00 € /ml

10.4



5

11.6

DOUCINE - GORGE

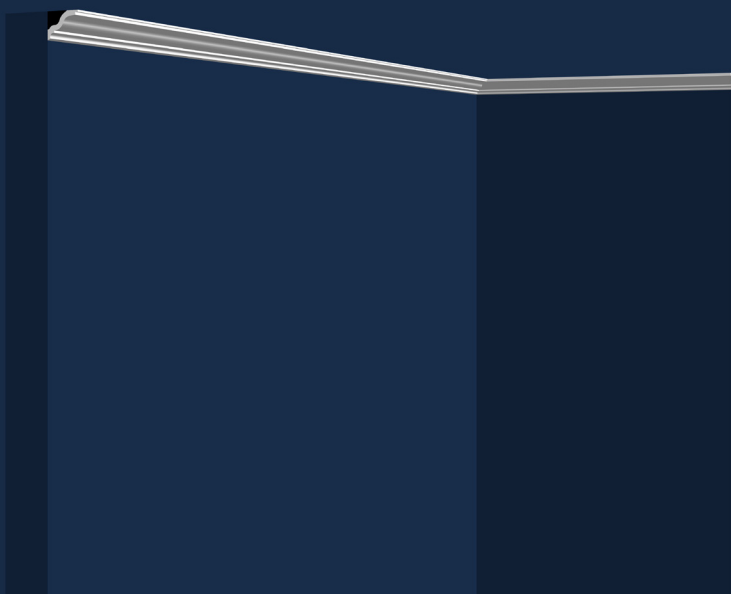

DONNEZAC

18.00 € /ml

6.9



5.3

8.7

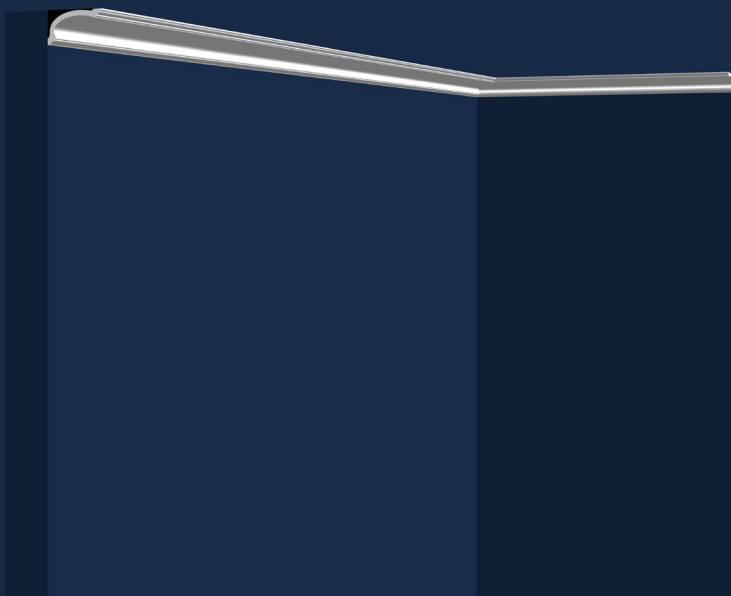

FLOIRAC

20.00 € /ml

12.2



6.2

13.7

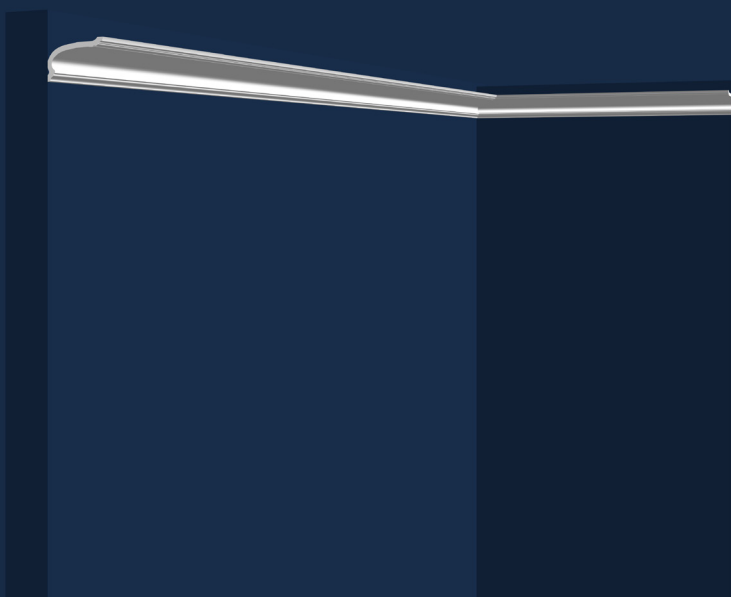

FRONSAC

22.00 € /ml

12.6



7.8

14.8

GORGE

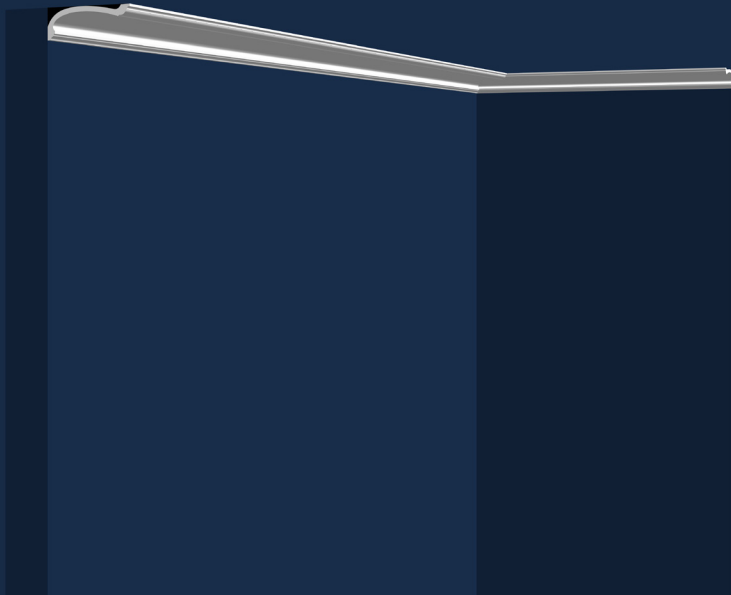

GABARNAC

30.00 € /ml

18.4



5.9

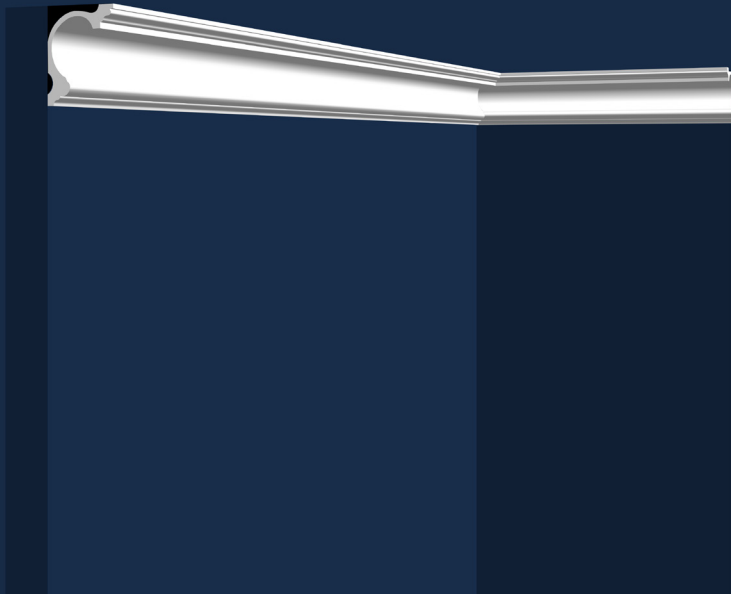

GREZILLAC

35.00 € /ml

14.8



18

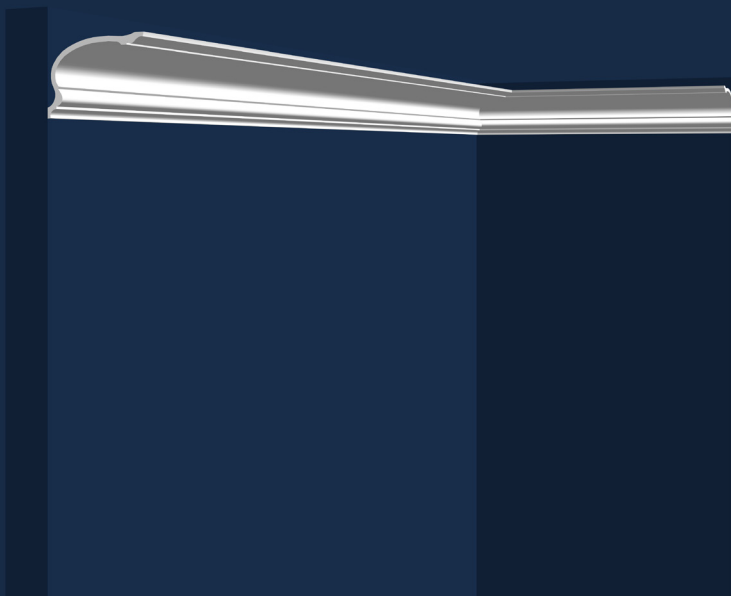

PAUILLAC

40.00 € /ml

21.4



15

GORGE

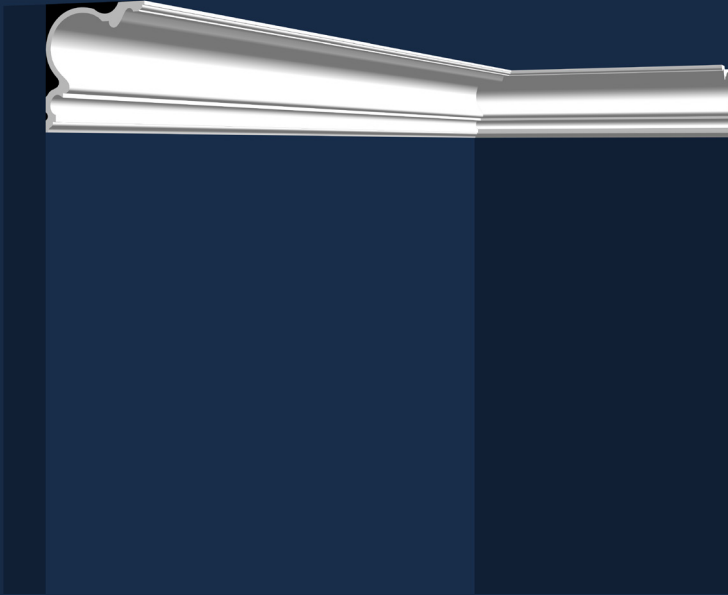

MONTIGNAC

50.00 € /ml

22



23

31.9

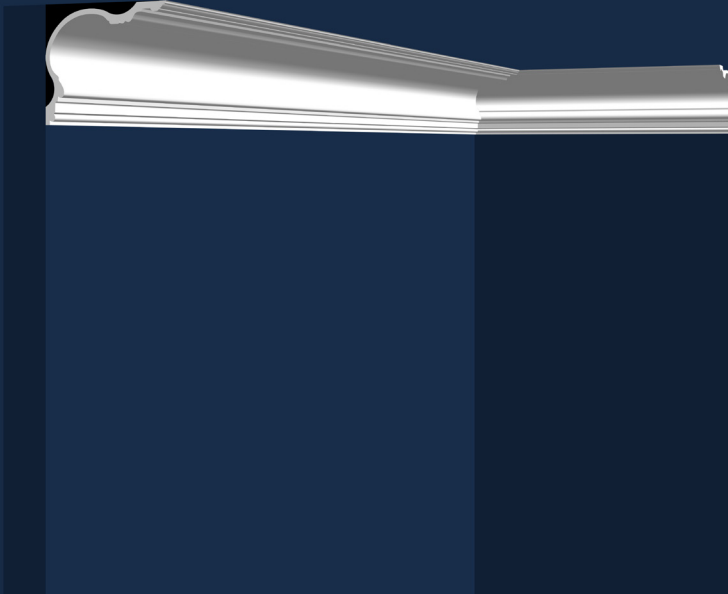

PODENSAC

50.00 € /ml

26.6



21.5

34.3

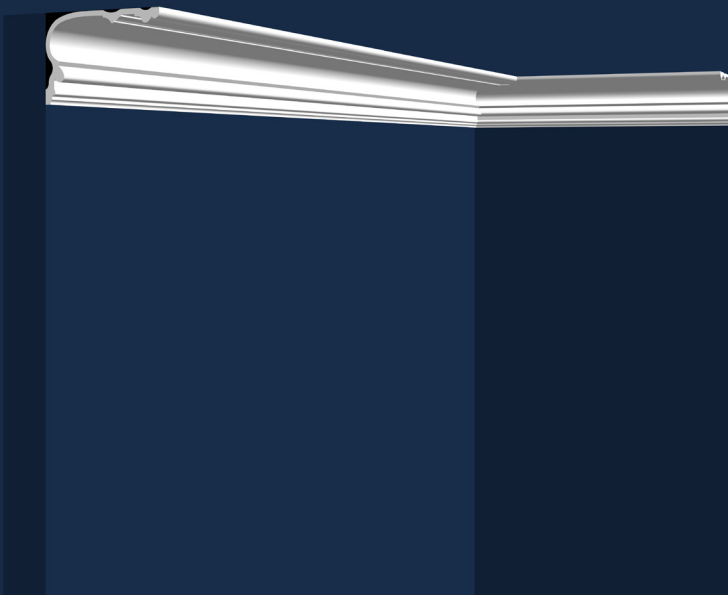

QUINSAC

42.00 € /ml

25.2



16.7

30.2

GORGE

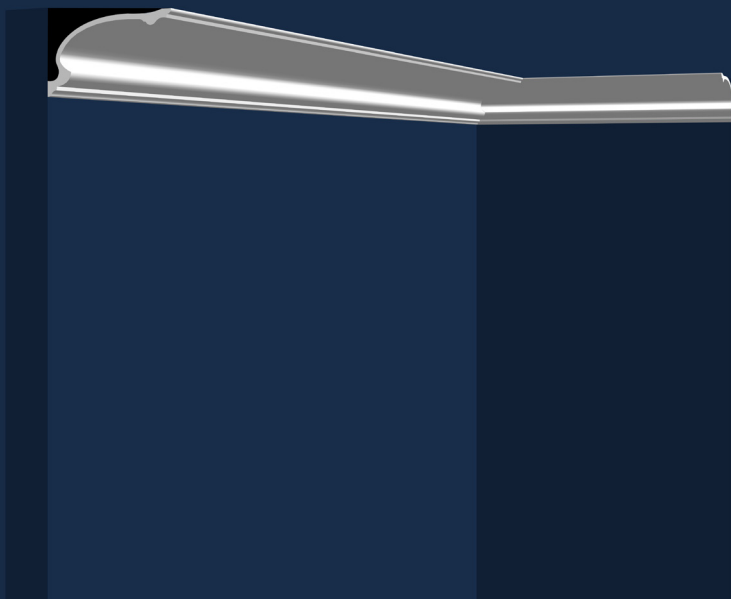

SADRAC

44.00 € /ml

27.2



14.9

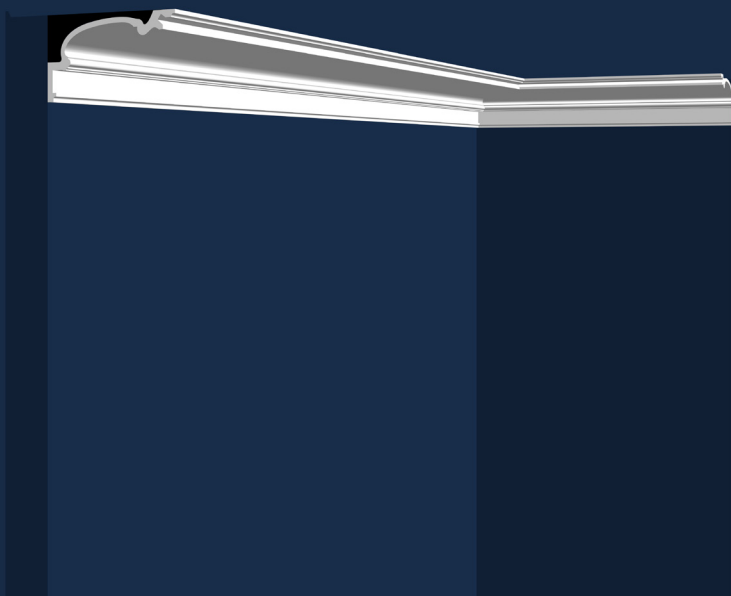

LESTIAC

46.00 € /ml

28.1



15.7

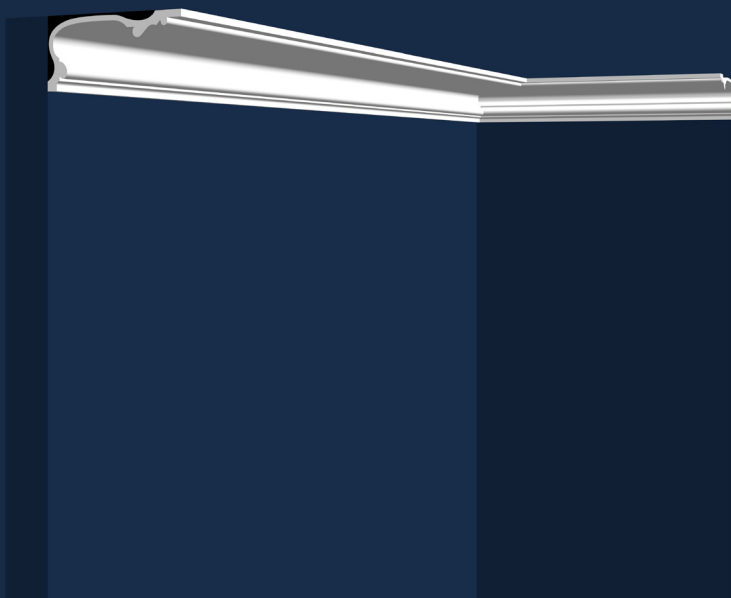

MERIGNAC

46.00 € /ml

29.3

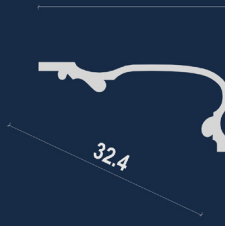

13.7

GORGE

LOUPIAC

50.00 € /ml

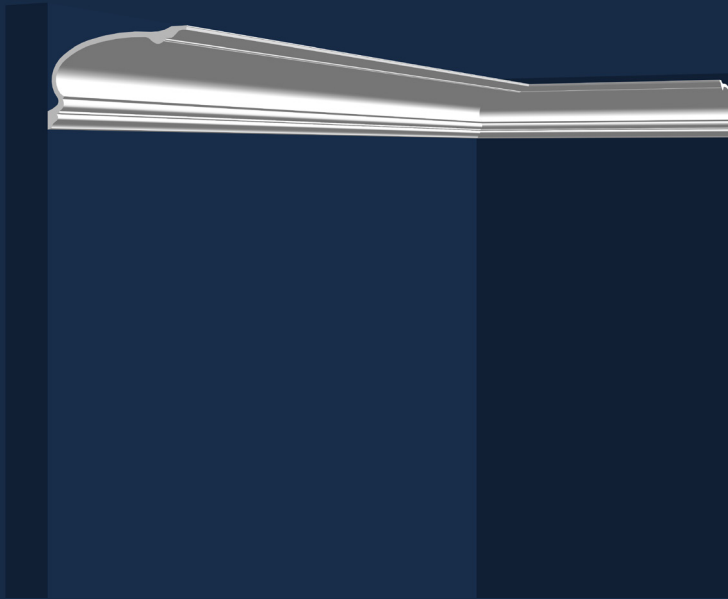

30.6



SOULAC

67.00 € /ml

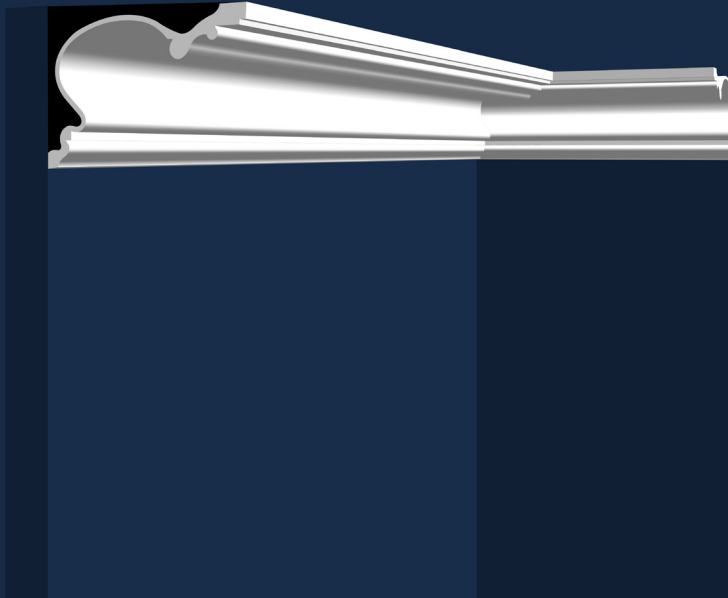

42.5



LARMIER

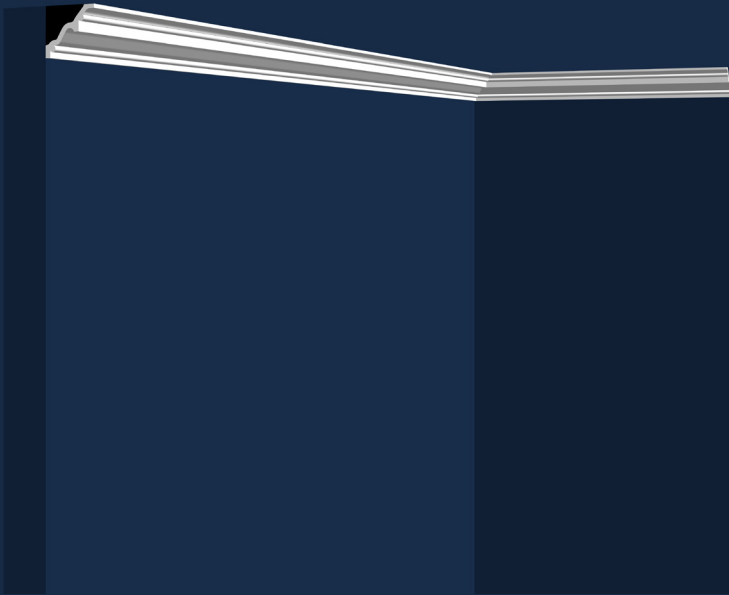

YVRAC

25.00 /ml

11



9.5

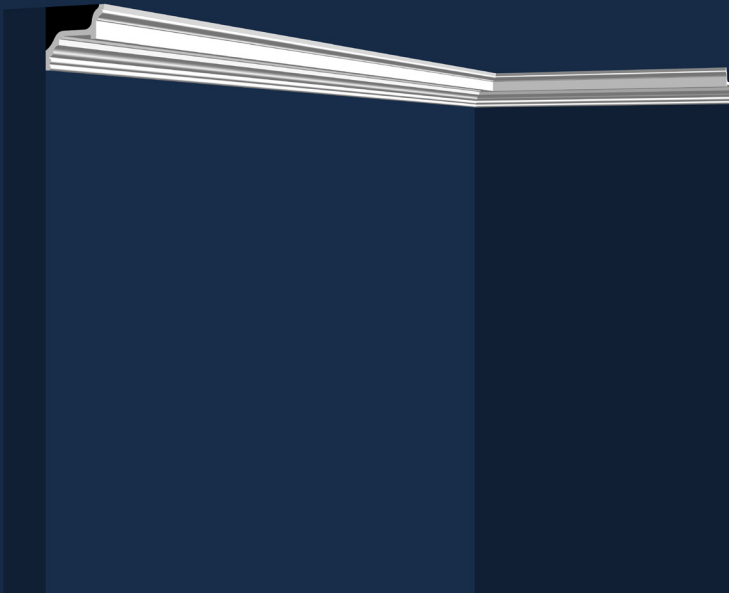

VERAC

25.00 € /ml

13.4



11.5

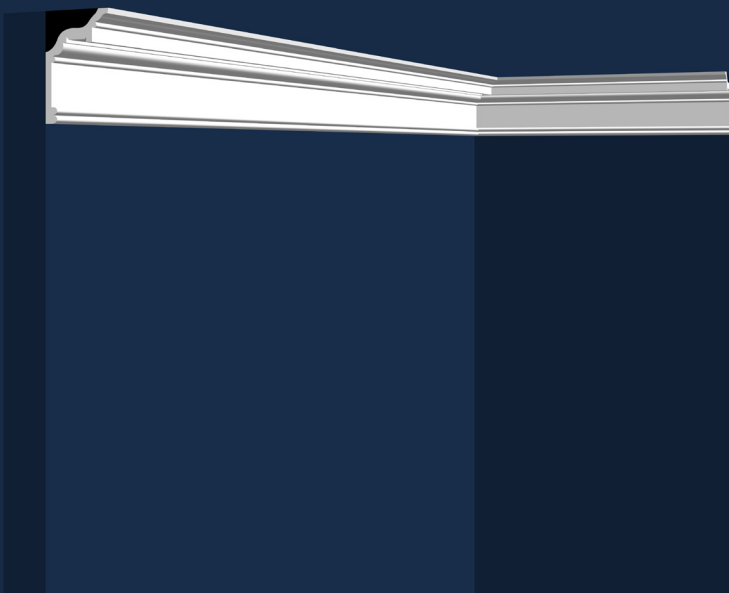

TABANAC

34.00 € /ml

14.2



20.5

L'ARMIER

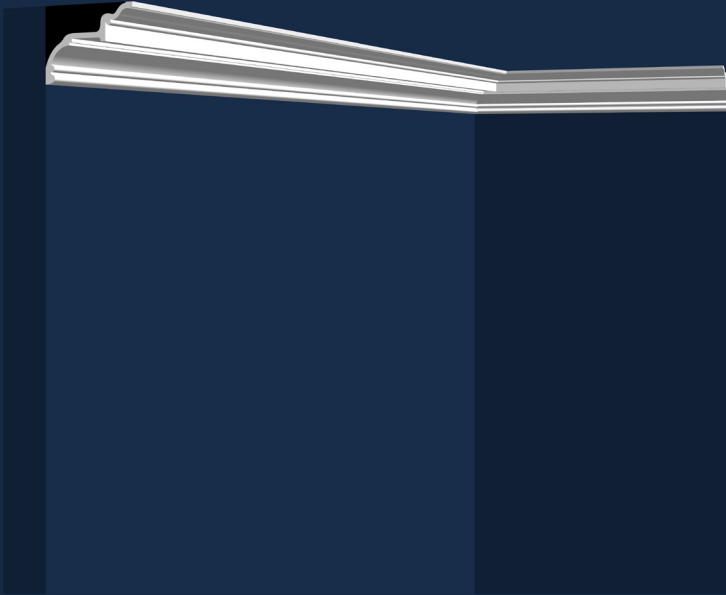

CANTENAC

35.00 € /ml

19.5



14.3

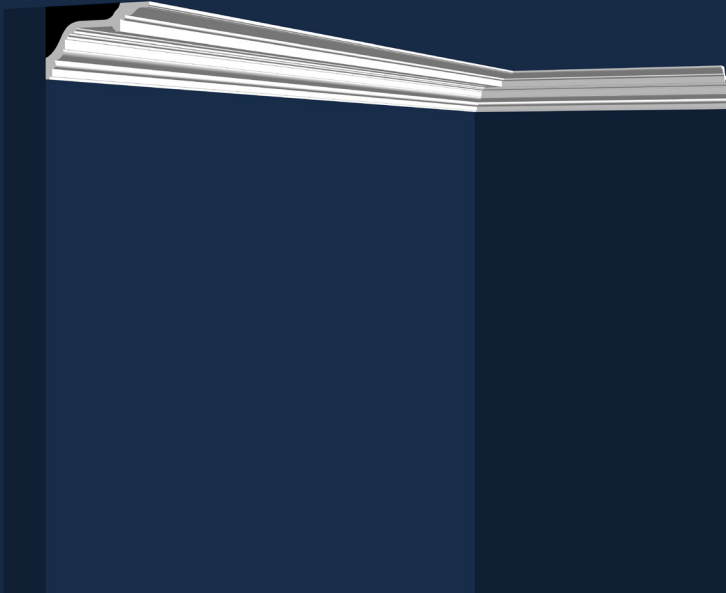

BARSAC

35.00 € /ml

23



13.2

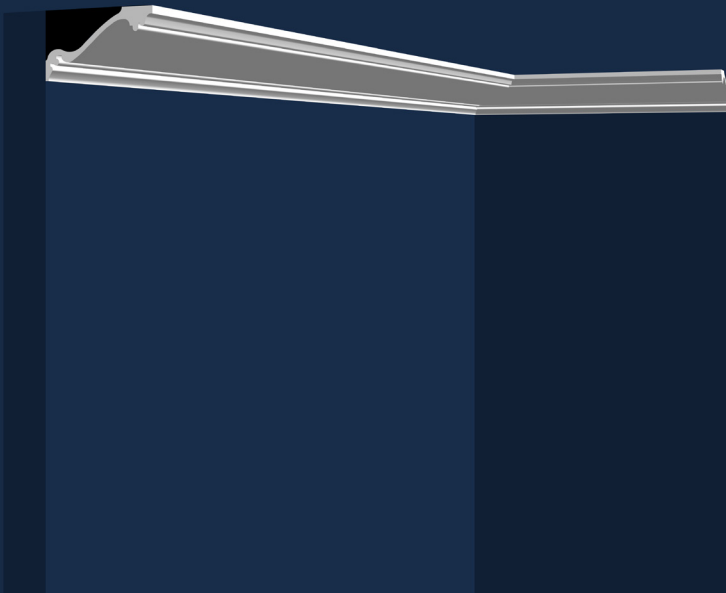

CENAC

32.00 € /ml

23.7

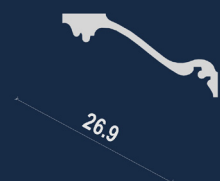

12.7

CLASSIQUE

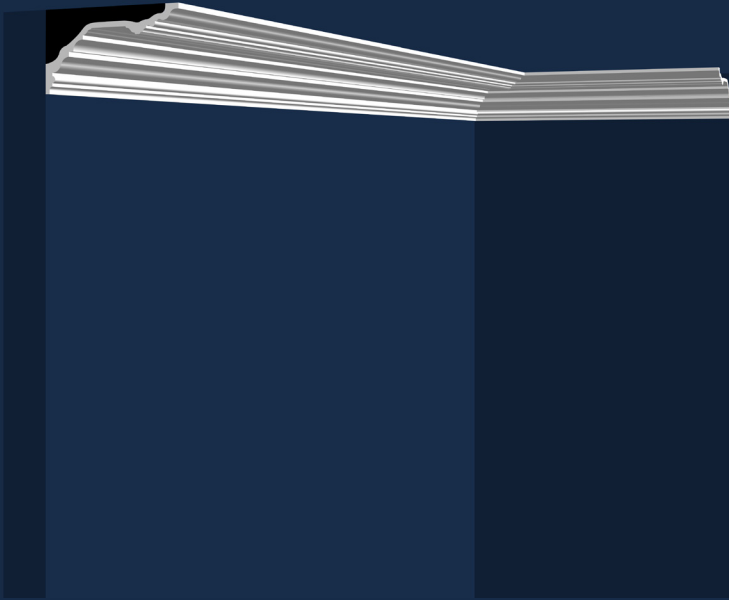

GÉNISSAC

45.00 € /ml

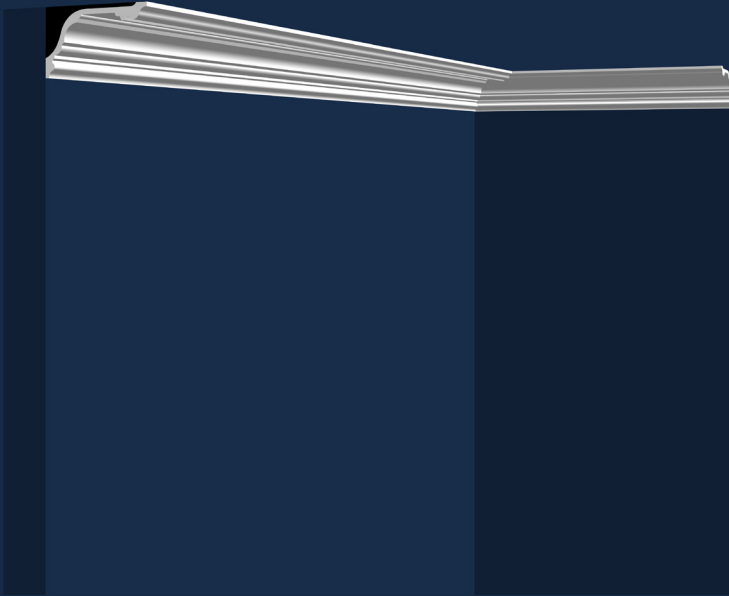
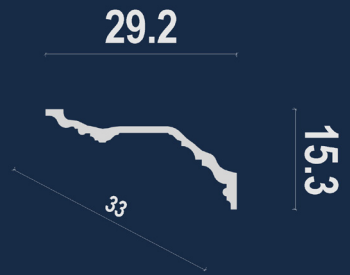

NAUJAC

34.00 € /ml

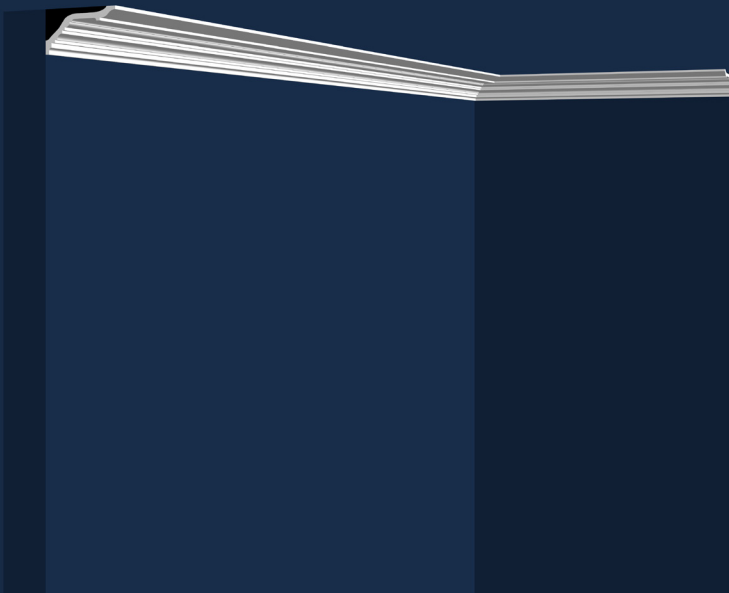
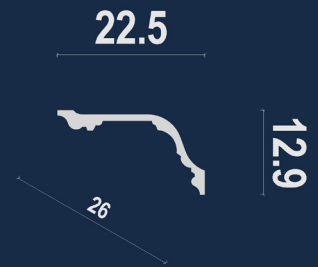

PUGNAC

28.00 € /ml







MOULURES ET CIMAISES

MOULURES

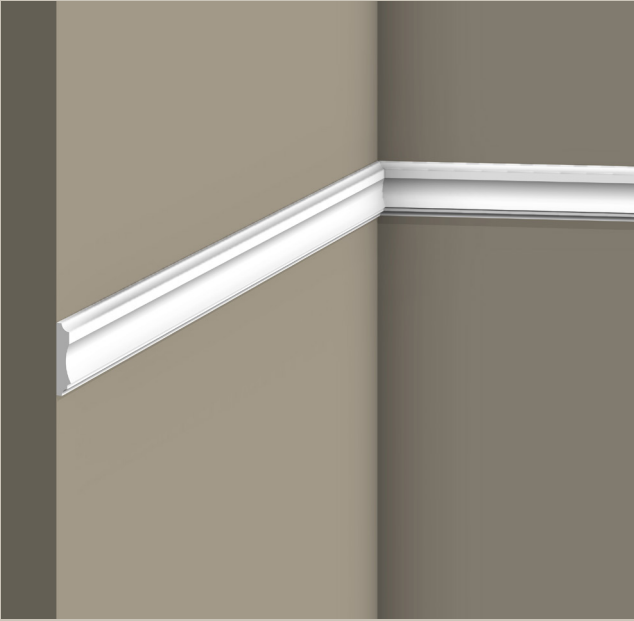

FRONTENAC

11.00 € /ml

1.2



5.4

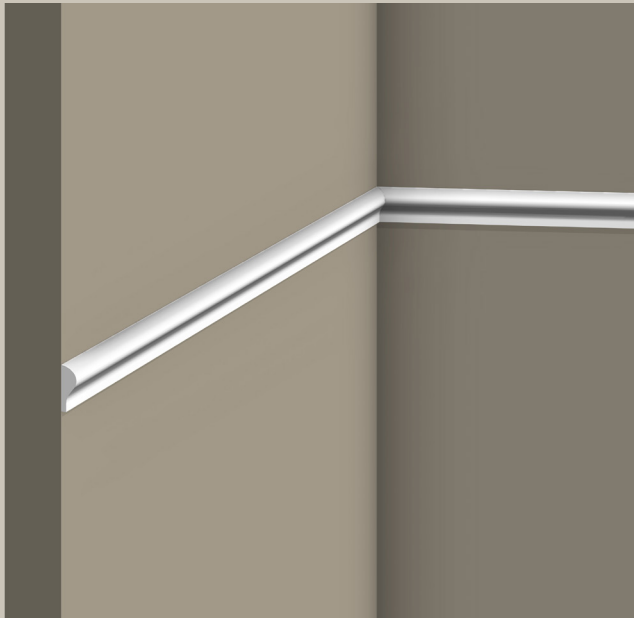

CAMARSAC

8.00 € /ml

1.3



3.5

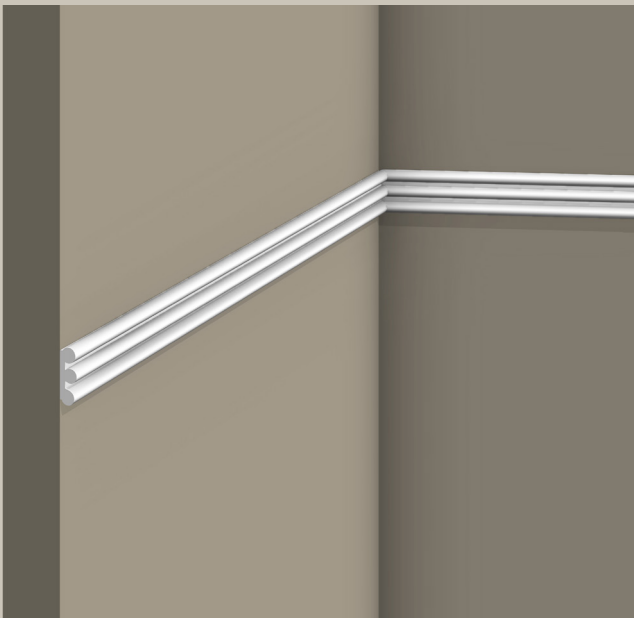

GAJAC

10.00 € /ml

1.4



3.7

MOULURES

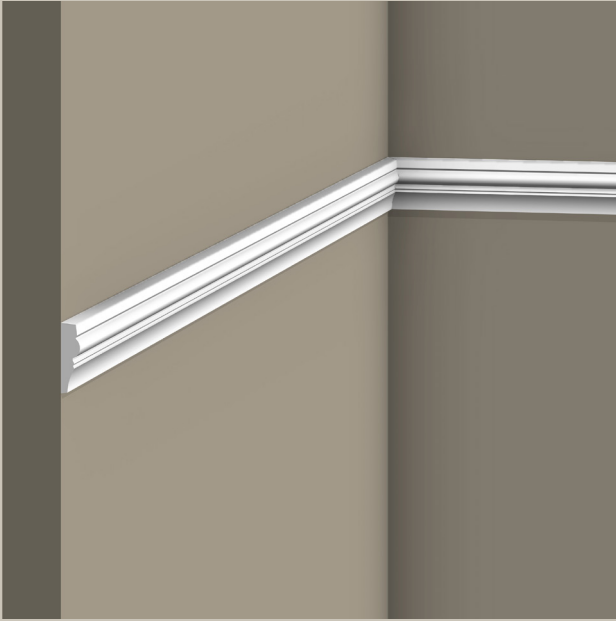

GAURIAC

10.00 € /ml

1.6



5.2

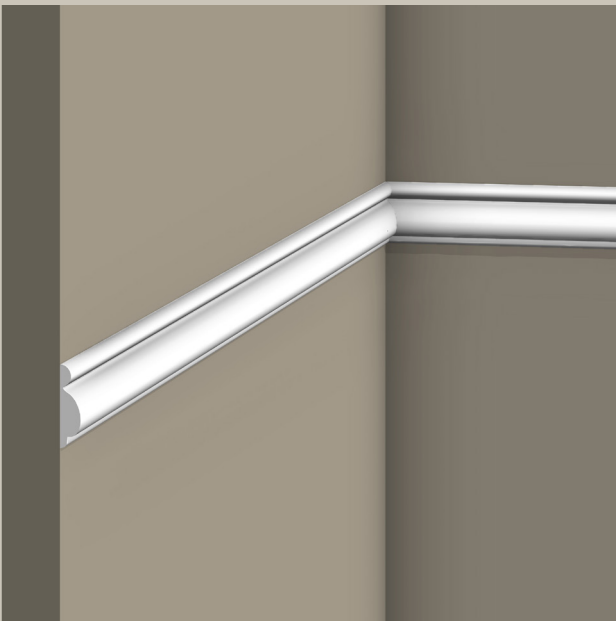

JUILLAC

12.00 € /ml

1.7



6.2



NÉAC

11.00 € /ml

1.7



5.5

MOULURES



MARTILLAC

17.00 € /ml

1.7



14.4

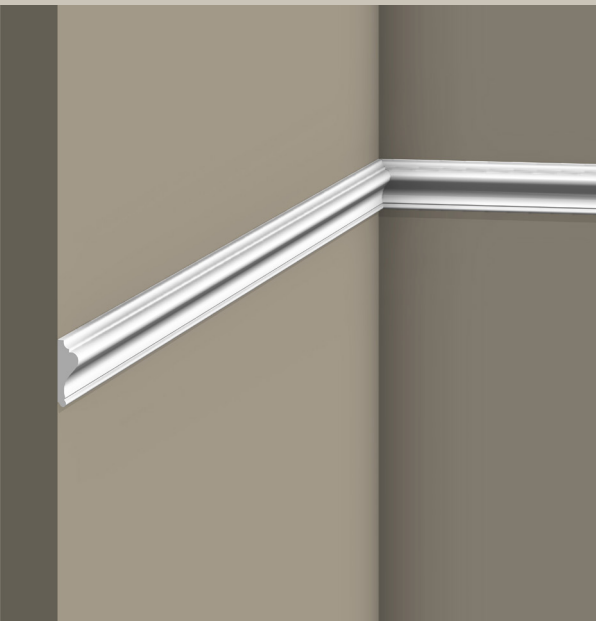

CAVIGNAC

11.00 € /ml

1.8



5

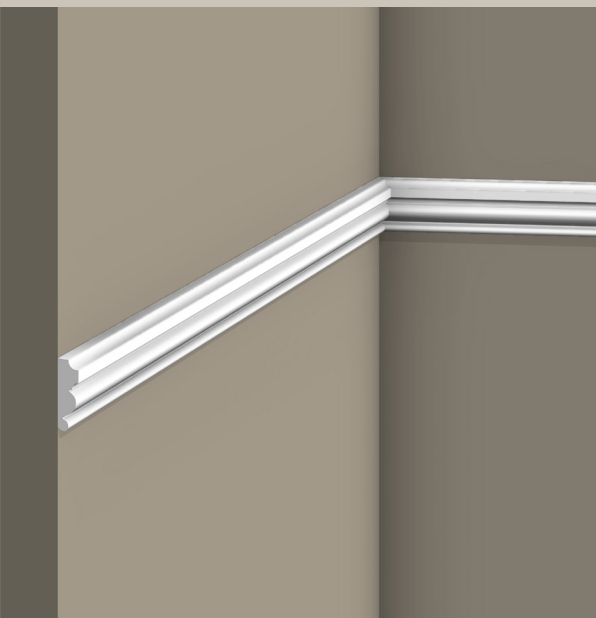

CÉZAC

11.00 € /ml

1.8



5.4



MOULURES

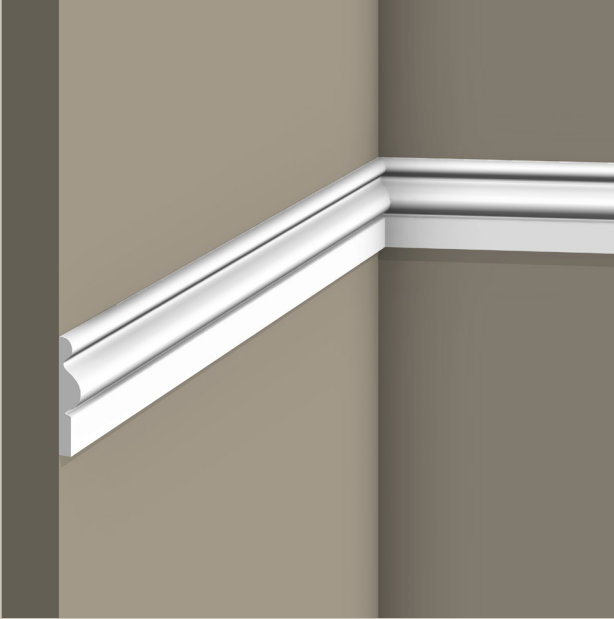

GORNAC

15.00 € /ml

1.9



8.9

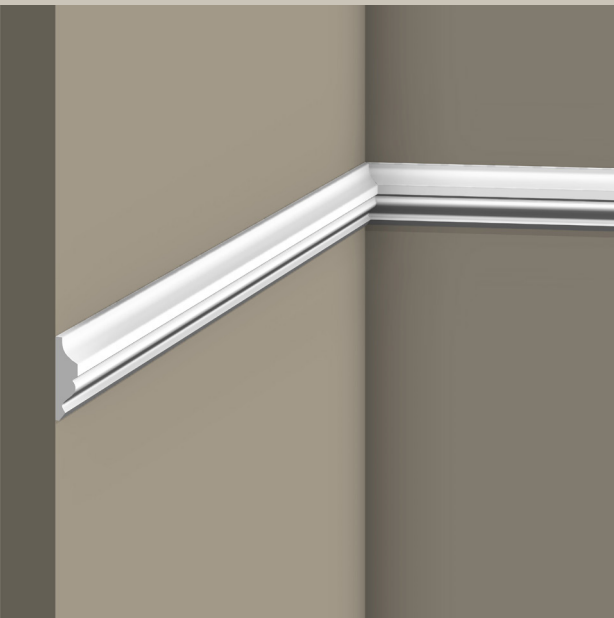

REIGNAC

15.00 € /ml

2



6.5



SAUVIAC

12.00 € /ml

2.1



5.1

MOULURES

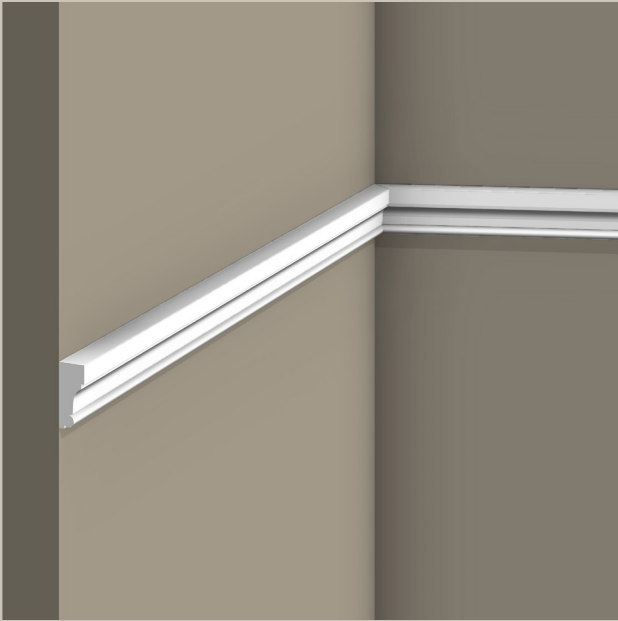

POMPIGNAC

11.00 € /ml

2.2



5

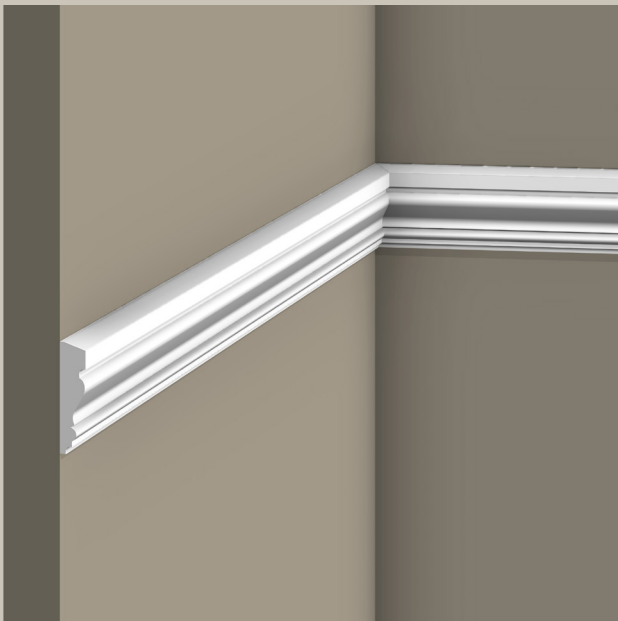

DONZAC

16.00 € /ml

2.2



8.5

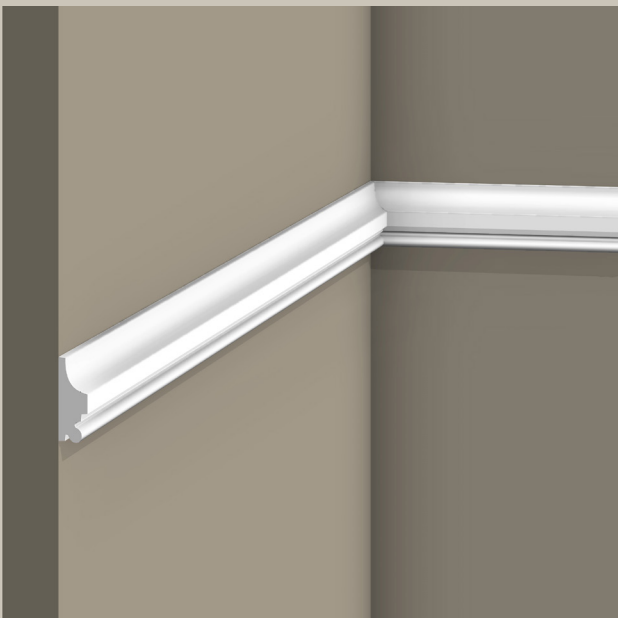

QUEYRAC

16.00 € /ml

2.6



6.5

MOULURES

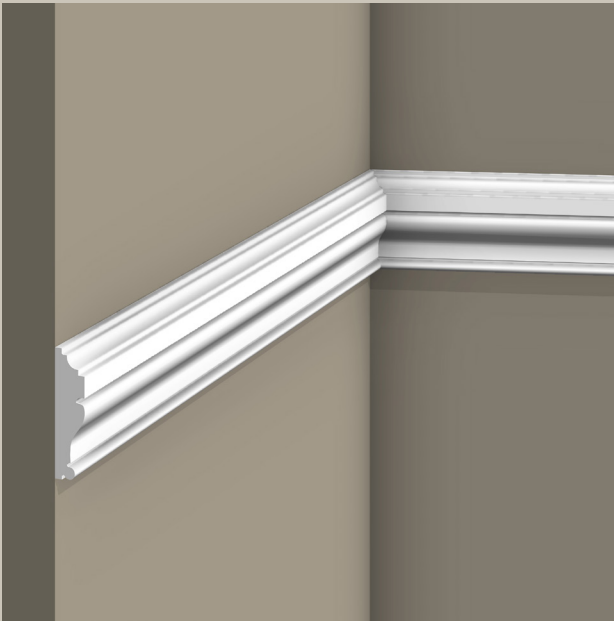

PERISSAC

16.00 € /ml

2.6



10



SAMONAC

15.00 € /ml

2.8



9.1

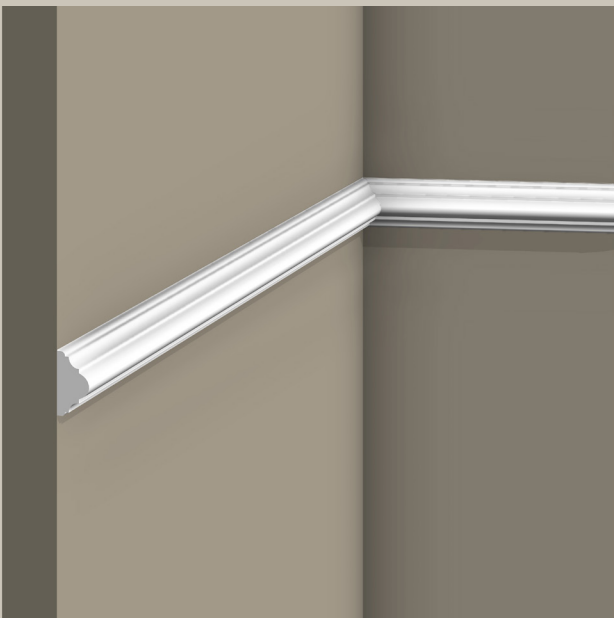

VALEYRAC

15.00 € /ml

2.9



5.1

MOULURES



CIVRAC

18.00 € /ml

3.1



12.1

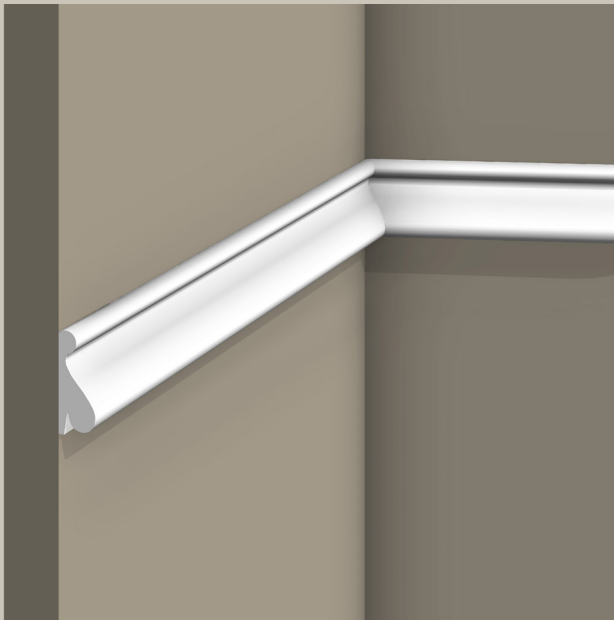

CISSAC

16.00 € /ml

3.3



8.2



COIRAC

15.00 € /ml

3.3



7.9

MOULURES

CADILLAC

15.00 € /ml

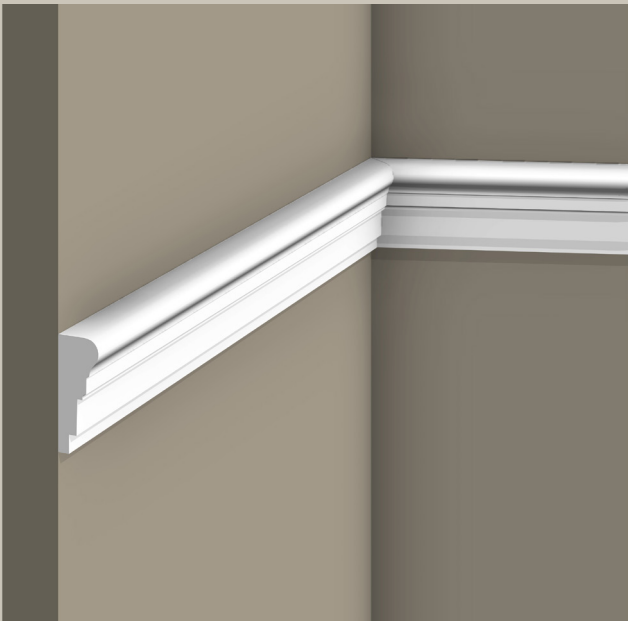

3.5



9.1



PLASSAC

18.00 € /ml

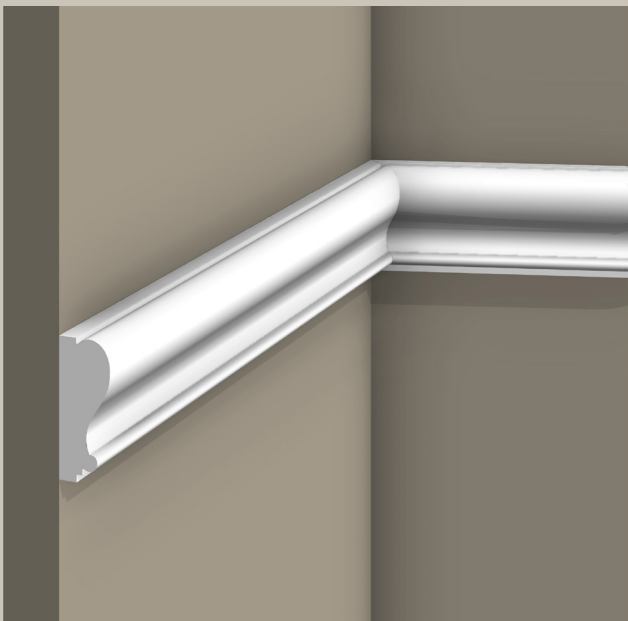

4.5



11.1



PREIGNAC

16.00 € /ml

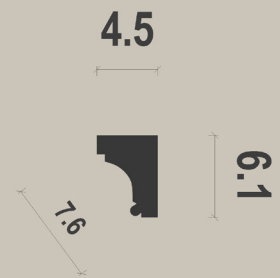
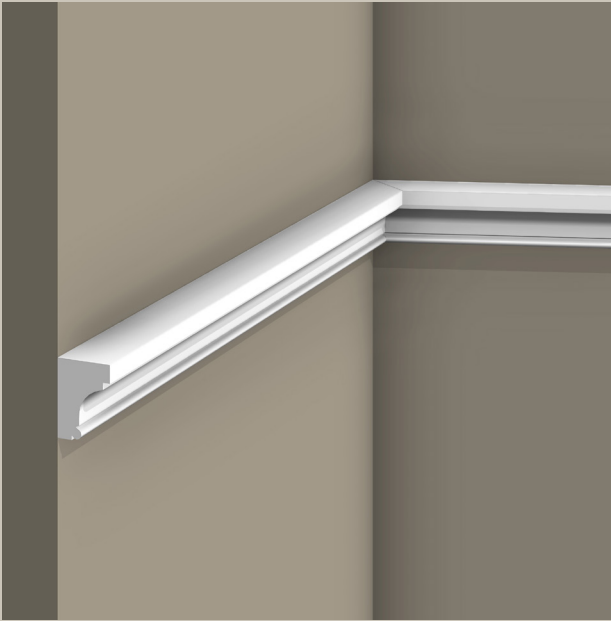

SOULIGNAC

19.00 € /ml

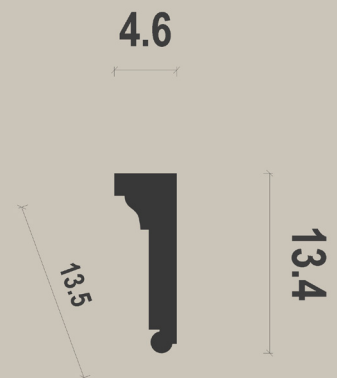
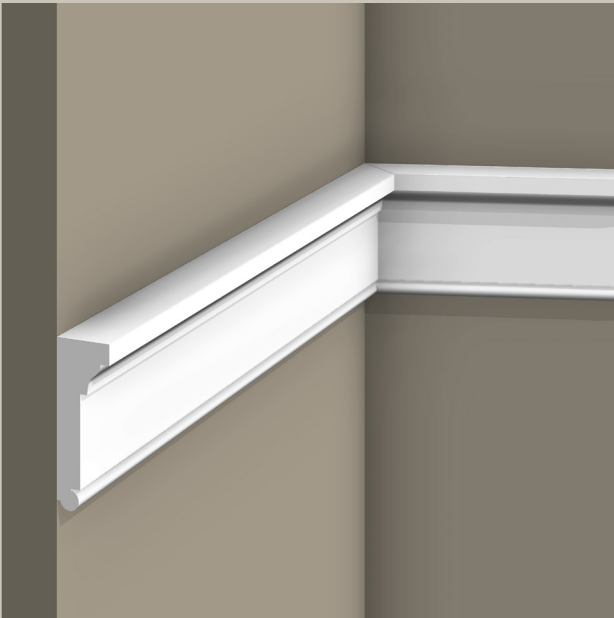

CADAUJAC

22.00 € /ml

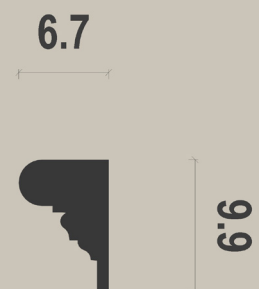
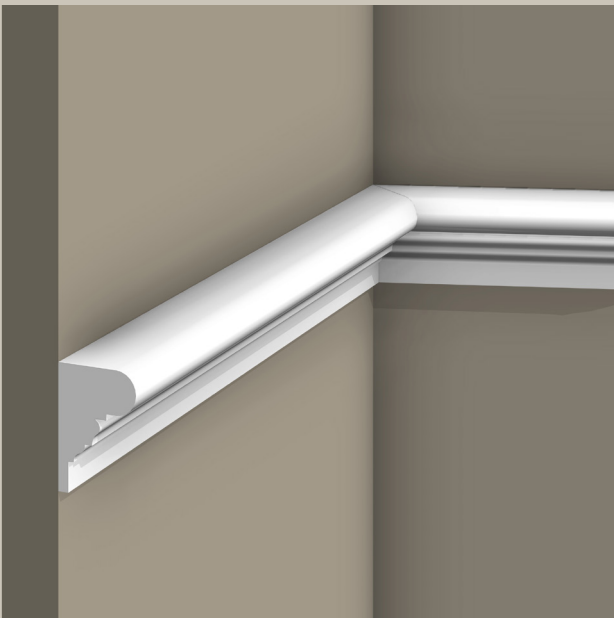





LES ROSACES



LÉOGNAN

170.00 € / U

58 cm

35 cm

BEGADAN

85.00 € / U





CAPIAN

75.00 € / U

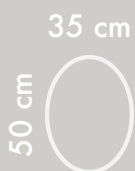

LANGOIRAN

100.00 € / U



CANÉJAN

100.00 € / U

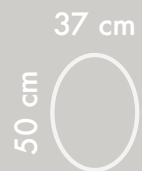

CARIGNAN
330.00 € / U

100 cm



CAUDÉLAN
685.00 € / U

140 cm



CARDAN

700.00 € / U





LES PANNEAUX



CESTAS

Prix et dimensions sur demande



LANDIRAS

Prix et dimensions sur demande

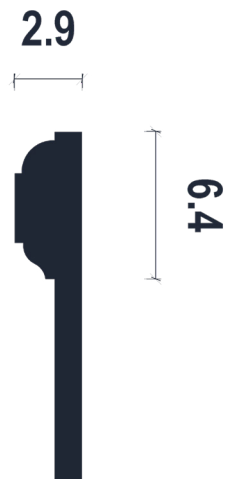

MARTIGNAS

Prix et dimensions sur demande

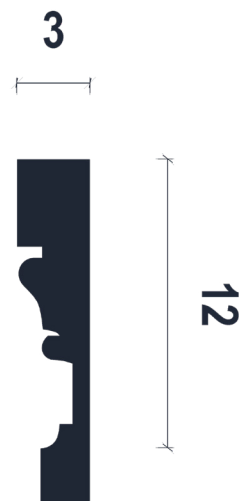



ILLATS

Prix et dimensions sur demande

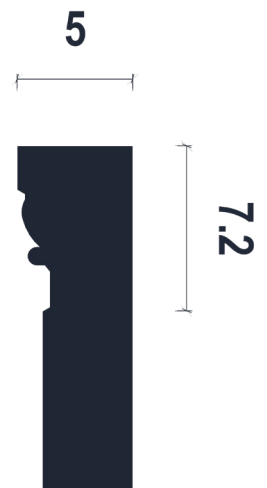

SAUCATS

Prix et dimensions sur demande

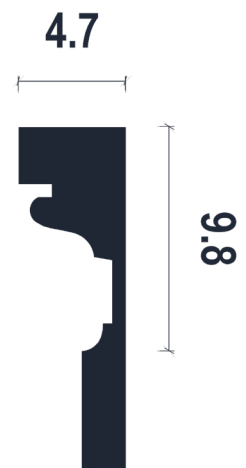

CHAMBRANLES ET PLINTHES





CRÉON

Prix sur demande

5.9



19.2

4.2

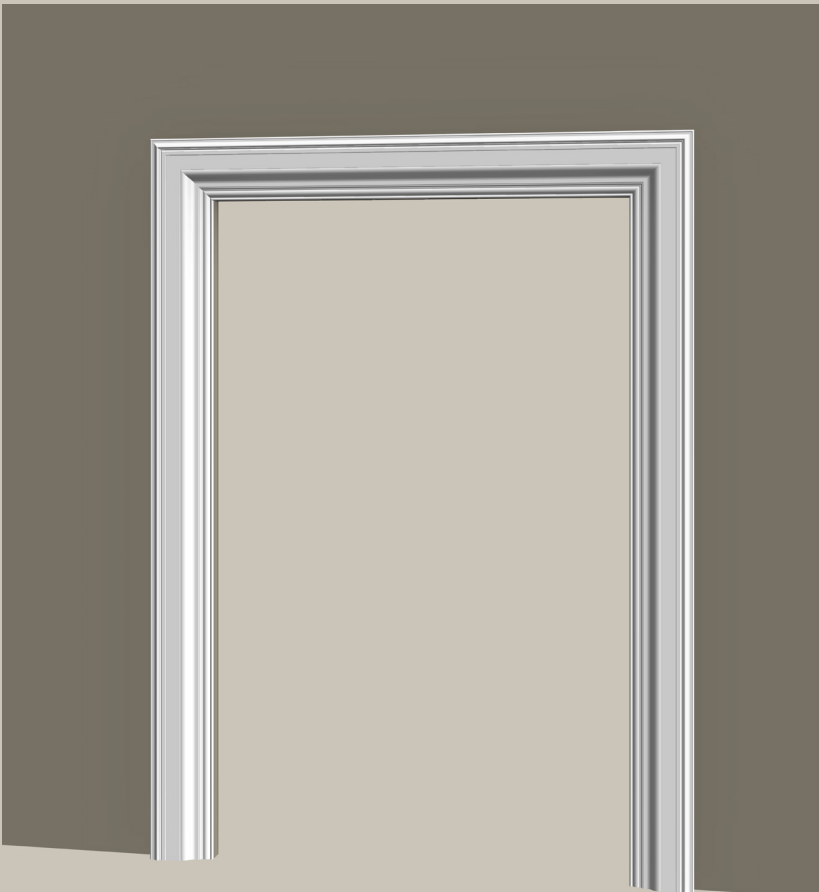

CRÉON B

Prix sur demande

5.9



19.2

4.2



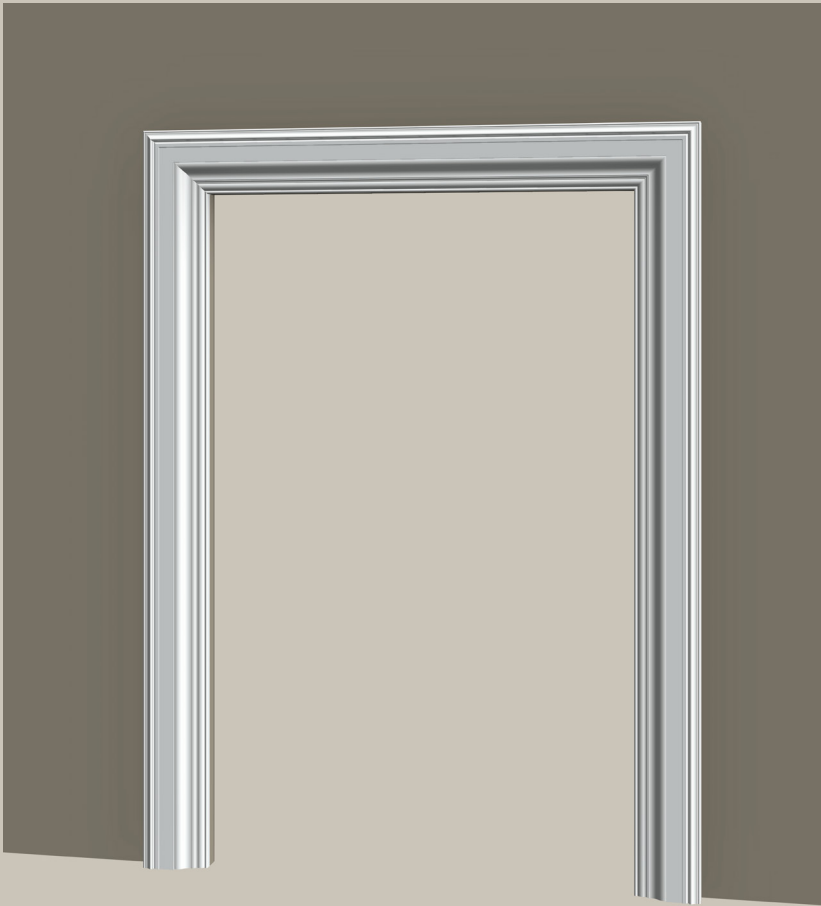

TARGON

Prix sur demande

7.4

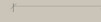

19.1

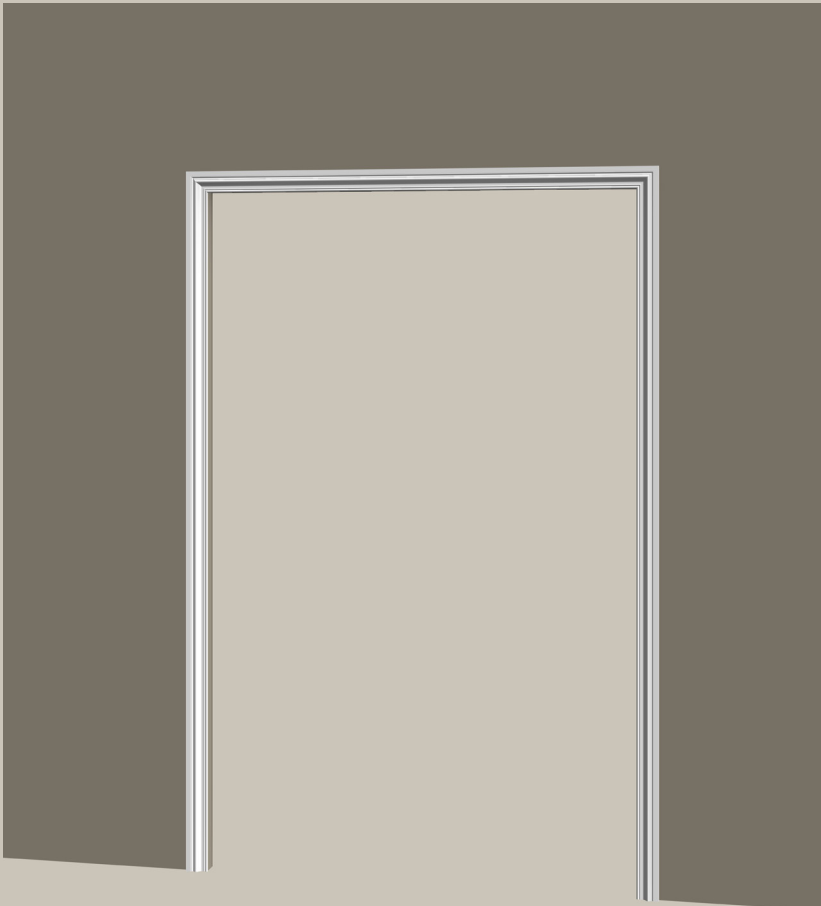

MORILLON

Prix sur demande

1.8



6.4





CÉRONS

11.00 € /ml

3



25.9

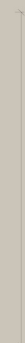

RIONS

15.00 € /ml

2.6



15.1





GARABOS

PLATRERIE - STAFF

Z.A LA JACQUOTTE - 33270 FLOIRAC

05 56 32 00 23

accueil@garabos.com



GROUPEMENT DES ENTREPRISES
DE RESTAURATION
DE MONUMENTS HISTORIQUES

